



SPM MACHINERIES PRIVATE LIMITED

REGISTERED OFFICE: L 404, AJNARA HOMES 121, SECTOR 121 NOIDA – 201301, UTTAR PRADESH

FACTORY / WORKS: G 307, SECTOR 63 NOIDA UP INDIA - 201301

PHONE & MOBILE NUMBERS: +91-120-418 98 66 & **+91-9250421026, +91-9532666555**

WEBSITES: www.kartikaysinternational.com, www.theconveyors.com, www.spm.technology, www.multimines.in

EMAILS: ki@kartikaysinternational.com, offers@multimines.in, offers@coopslen.com, rk@spm.technology

MFG: ALL KIND OF MECHANICAL CONVEYOR COMPONENTS, ELECTRO-MECHANICAL AUTOMATIONS, AN ENGINEERING SOLUTIONS

QUOTE AUTHENTICATION NUMBER (C D M Y S)

REF NO: SPM-----11G(08)22-1122

DATE: 16 – AUG - 2022

Company Name: **NB FARMERS PRODUCERS COMPANY**

Address: RAMTEK

City/State: NAGPUR – 441106, MAHARASHTRA

Country: **INDIA**

Phone No.: +91 – MOB NO: +91 – 81493 25719

Email: nbfarmers2021@gmail.com; kdt51990@gmail.com

Name/Department: **MR. KULBHUSHAN TEMBHRUNE**

Subject: QUOTATION FOR STAINLESS STEEL 304 GRADE LINEAR TYPE VEGETABLE WASHING MACHINE 1000 KG/PH

Dear Sir / Madam,

Sir, as per our dissection had with you regarding WASHING MACHINE to Wash **Green Chili Products**, we have gone through your requirements & willing to inform you that we are able to supply suitable machines for your packaging needs.

We offer you our models **KI-SS/LWM/1K-PH, KI-SS/RGM/0.2K-PH, KI-SS/LCM/0.2K-PH**

May I request you to please go on **page no. 2 to 3** check machine technical specification, offer price and **page no. 4** our terms and conditions & If you have any questions regarding same Ginger Process & Packer Price or any technical details, please feel free to contact us by business contact phone **Call +919250421026, +919532666555** or **E-mail at kimachines@hotmail.com & spmmachines@hotmail.com** we will be happy to help you any time.

We are confident that you will be very satisfied with the services that we offer.

Hope to get your response as soon as possible along with your purchase order and we look forward a long-time business relation with you and your company.

Sincerely,

SPM MACHINERIES PVT LTD (SPM-MACHINES)

RUPESH K MISHRA
(DIRECTOR)

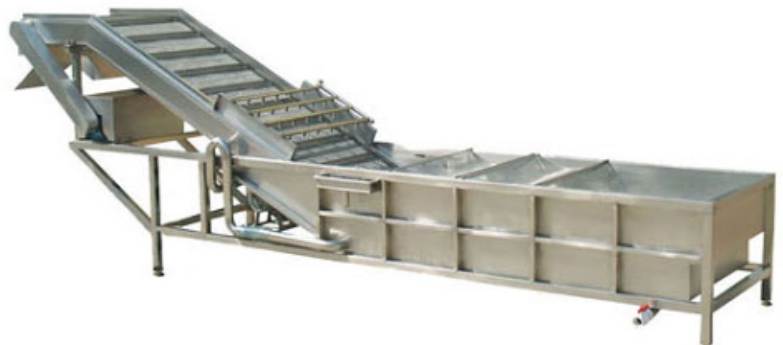

MACHINE NAME & SEGMENT	QTY	UNIT PRICE	TOTAL PRICE (EXW)
1. LINEAR STAINLESS STEEL WASHING MACHINE 300 KG* P/H OUTPUT	01	4, 10, 000	4, 10, 000.00 INR

This machine is suitable for washing different solid vegetables with sprinkler and many high-pressure jets to cleaning the material.

- The machine equipped with circulating water pump and filter water tank, realizing cycle use to save cleaning water (if needs new water change and supplement according to actual processing production).
- The machine adopting high pressure water jet flow for washing with great cleaning capacity with high impurities reduction efficiency of product which need to be clean.
- The machine pressure adjustment function. The processed product is delivered by a net chain with an automatic feeding / manual feeding and discharging, and the speed of delivering wire mesh stainless steel belt can be adjust on basis of production requirements match according to demand.
- The machine design totally made of stainless-steel prime material with cooled roll (CR) with 304 food grade segments.
- The Dimension of same machine for achieved same output get is 3000 x 800 x 1000 mm* (L x D x H)
- The thickness of stainless-steel material very high gauge uses in same machine strength maintain.
- The connected load in same machine 1.0 HP with three phase supply with 50 Hz current voltage
- The bearing use in same machine block type UCP-206, 205 for levelling and pressure free rotation.
- The machine has variable speed control system for maintain the output target of production.
- Side Brushes remove dust and mud from the product properly with continues motion feeding.

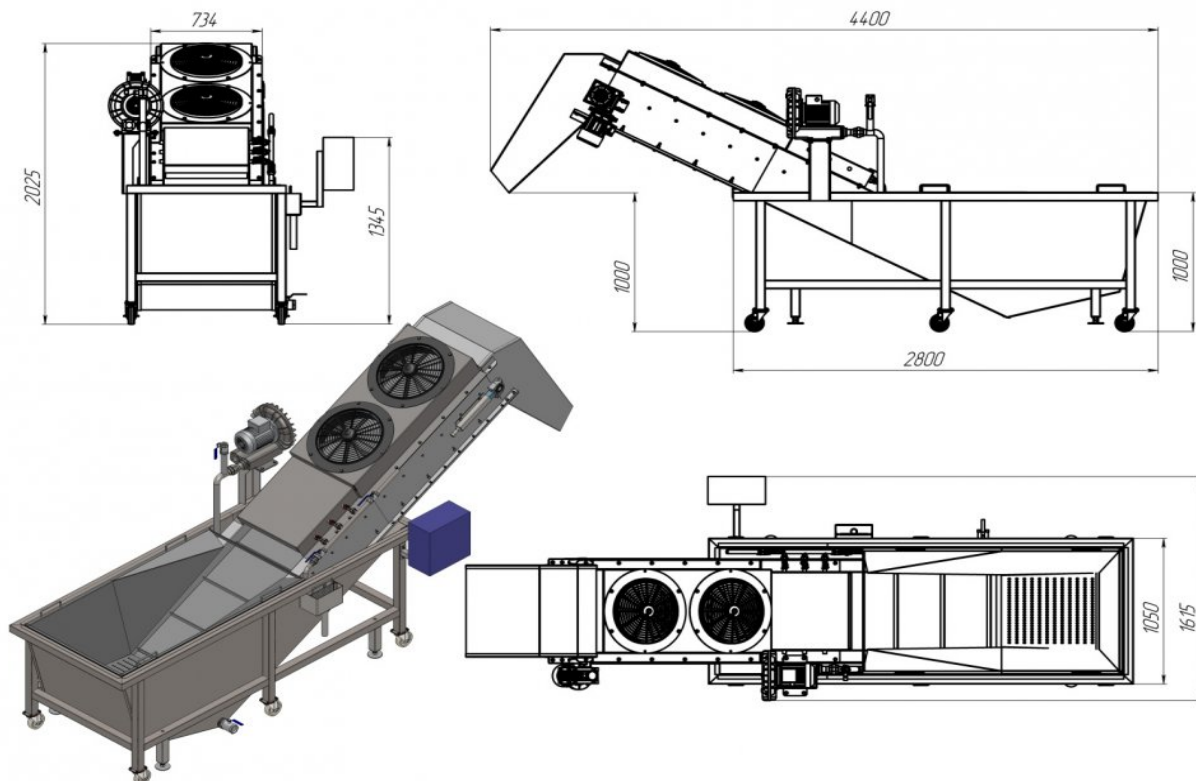

MACHINE NAME & SEGMENT

1. ROLLER SIEVE TUMBLER (SEPARATOR DRUM)

- Contact Structure: S.S. 304 Food Grade
- Sieve Length: 8.0 Feet's
- Roller Drum Dia: 800 MM*
- Storage tray for unmatched sizes
- Connected Load: 1 H.P. with Drive
- Connectivity with 3 Phase

VIBRATORY FEEDING SYSTEM WITH TRAY

- Structure: S.S. 304 Food Grade
- Tray Length: 3 Feet's
- Vibrator controller: attached with digitally controlled
- Heavy duty coil for vibration

MACHINE NAME & SEGMENT	QTY	UNIT PRICE	TOTAL PRICE (EXW)
1. ROLLER SIEVE TUMBLER (SEPARATOR DRUM)	01	2, 50, 000	2, 50, 000.00 INR



MACHINE NAME & SEGMENT

2. STAINLESS STEEL COOLING CONVEYOR WITH SIDE PLATFORM

MACHINE NAME & SEGMENT	QTY	UNIT PRICE	TOTAL PRICE (EXW)
2. STAINLESS STEEL COOLING CONVEYOR WITH SIDE PLATFORM	01	2, 50, 000	2, 50, 000.00 INR

1. Equipment description	Straight Guide Belt Conveyor
2. Total Conveyor Length	5.0 Meters
3. Conveyor Vertical Top Height	3.0 & 3.0 Feet's
4. Conveying Capacity	5 KG Per Meters*
5. Conveying Speed	Variable Type, Max speed at 80-100 RPM
6. Belt Conveyor Fabrication	
a) Sheet Material for Structure	Cold Roll Stainless Steel
b) Sheet material for Covering	Cold Roll Stainless Steel
c) Body Final Color	Finished
c) Feeding Hopper	Not Applicable
c) Thickness of Sheet	1.5 mm
d) Type of Joint	Yes Joint
e) Thickness of Joint	5.0 mm Hot Rolled Stainless Steel
f) Width of Outer Section	1100 mm*
g) Width of Inner Section	700 mm

7. Roller & Shaft Specifications

a) Construction Roller	MS Hard Grade
b) Roller Type	Metal
c) Rubber Type	Not Applicable
d) Total Roller Dia	100 mm*
e) Rubber Thickness in Roller	Not Applicable
f) All Shaft Material	MS Hard
g) Bearings Use	UCF 205, UCT 205, 6006, 6005, 6004 (Make: Block & Ball)
h) Sealing	Lifetime double sealed & dust proof ball bearings – lubricated & packed for life



SPM MACHINERIES PRIVATE LIMITED



REGISTERED OFFICE: L 404, AJNARA HOMES 121, SECTOR 121 NOIDA – 201301, UTTAR PRADESH

FACTORY / WORKS: G 307, SECTOR 63 NOIDA UP INDIA - 201301

PHONE & MOBILE NUMBERS: +91-120-418 98 66 & **+91-9250421026, +91-9532666555**

WEBSITES: www.kartikaysinternational.com, www.theconveyors.com, www.spm.technology, www.multimines.in

EMAILS: ki@kartikaysinternational.com, offers@multimines.in, offers@coopslen.com, rk@spm.technology

MFG: ALL KIND OF MECHANICAL CONVEYOR COMPONENTS, ELECTRO-MECHANICAL AUTOMATIONS, AN ENGINEERING SOLUTIONS



i) Another Shaft Motor Couple	30 mm Dia
8. Belt Specification & Idler Rollers	
a) Belt Type	Mesh Type
b) Cleat	Not Available
c) Cleat Pitch	Not Available
d) Cleat Height	Not Available
e) Cleat Joint	Not Available
f) Side Wall Cleat	Not Applicable
g) Return Roller	Yes Available
h) belt Alignment Roller	Yes Available
i) Belt thickness	1.2 mm
9. Salient Features of Conveyor	
a) Conveyor Structure	With Joint
b) Functioning	Yes Available fixed straight Faculty
c) Material Discharge	Yes Available
d) Number of Discharge	Single Discharge
e) Controlled	Yes Available
f) Fan Cooling	Yes Applicable
g) Return Roller Assembly	Yes Applicable
h) Air Knife Cleaning	Not Applicable
i) Side Guides	Yes, Available up to 50 mm
10. Electrical Features of Conveyor	
a) Operating parameters	3 Phase, 415 V, 50 Hz, AC power supply
b) Motor Type & Make	Worm Type & Motovario, Rotomotiv, ABB, Havelles
c) Variable Frequency Drive	Not Available if applicable so that cost optional (Schneider, Crompton, Delta)
d) IR Sensor Make	Yes Applicable (Buyers Scope) if need to be counting of sacks
e) Motor Load Rating & Box	2.0 HP & 75 mm (MOTOR GEAR SPECIFICATION CHANGE AS PER LOAD)
f) WITHOUT LOAD MOTOR RPM	1440 RPM
g) Final RPM	80 – 100 rpm @ 50 Hz/as per your requirement
i) Service factor	1.5
j) Final drive	Coupling Joint
k) Operation	Continuous movement (Three Phase Power Supply)
l) Electrical panel	Will be provided housing Overload Controlled
11. Benefits of Belt Conveyor	
a) Running Type	Straight
b) Product Travel	Smooth Continues Running
c) Reduce Man Power	Extra man Power removes in continues motion
d) Working	Smooth Continues Type
e) Area Consume	As Per Drawing
f) Finish	Stainless Steel

MACHINE NAME & SEGMENT	QTY	UNIT PRICE	TOTAL PRICE (EXW)
4. STAINLESS STEEL LINEAR TYPE CHILI GRADING MACHINE	01	16, 50, 000	16, 50, 000.00 INR

Product Type	Green Chili
Product Application	Vegetables
Grading Capacity	1000 KG Per Hour*
Grading Type	Liner Gap Grading
Feeding System	Conveying feed infeed tray
Drive	1.0 HP With Single Phase Industrial Supply (MAKE): (SIEMENS, CROMPTON, DELTA, L&T)
Gear Box	with Couple Worm Joint Direct Shaft Fixed (MAKE): (MOTOVARIO, ULTRAVARIO, ROTOMOTIV)
Body Type	Stainless Steel with 304 Prime Grade finished
Machine Covering Type	Fully Stainless Steel
Dimensions	3000 x 1000 x 1000 mm*
Operating systems	CONTINUES
Bottom Mesh Tray	Yes Available
Output Cooling Fan	Optional Cost if need
Main Motor	1.0 HP With Three Phase Industrial Supply (MAKE): (CGL, ABB, MOTOVARIO, ULTRAVARIO)
Gear Box Size	75 MM for 1.0 HP
Volt Meter / AMP. Meter	Digitally Display voltage indication
Safety features	Emergency Switch programmed Fault Error & Panel Cooling Fan
Output Tray	Attached inclined tray when have output conveyor
Output Conveyor	Linear Type with 4 Rows
Compressed Air Cleaning	Optional Cost if required 6 CFM @ 6 Bar (Depending on Attachments)
Total Power Consumption	3.0 KW
Speed Output	Depend on the cycle and uses of working hours
Electrical MCB & Switches	(MAKE: Siemens, Schneider, Au-tonics, Warner, ABB)
Electrical Supply	220 V /AC / Single Phase / 50 HZ OR 440 V /AC Three Phase /50 Hz
Machine weight	600 Kg. Approx.

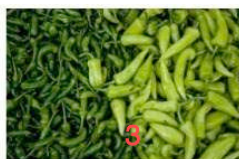



SPM MACHINERIES PRIVATE LIMITED



REGISTERED OFFICE: L 404, AJNARA HOMES 121, SECTOR 121 NOIDA – 201301, UTTAR PRADESH

FACTORY / WORKS: G 307, SECTOR 63 NOIDA UP INDIA - 201301

PHONE & MOBILE NUMBERS: +91-120-418 98 66 & **+91-9250421026, +91-9532666555**

WEBSITES: www.kartikaysinternational.com, www.theconveyors.com, www.spm.technology, www.multimines.in

EMAILS: ki@kartikaysinternational.com, offers@multimines.in, offers@coopslen.com, rk@spm.technology

MGF: ALL KIND OF MECHANICAL CONVEYOR COMPONENTS, ELECTRO-MECHANICAL AUTOMATIONS, AN ENGINEERING SOLUTIONS



1. General Terms & Disputes:

In case any kind of dispute creates so, sole legal formalities and others terms consider only Noida Uttar Pradesh (India) Jurisdiction Consider for settlements.

2. Safety Packing, Taxes, Insurance & Routing:

All Machines & Spare Parts prices always **EX-Works NOIDA** also exclusive of wooden or Crate Box for Safe packing, Transit Insurance & Freight, as well as all kind of any **TAXES** and any other Govt. levies born by Buyer side only. All machineries prices include our standard type complete resin stretch film packing along with safety standard. **(Spare parts packing charges as actual as per size.)**

3. Validity of Technical / Commercial Quote:

The quotation is open for acceptance for the period stated therein, or where no period is stated, it will lapse 14 days after the date thereof unless it is withdrawn earlier. If any firm order is not received any advance along with any kind of other more relevant documents/within this period, prices and other terms will be subject to change as per Target dates from supplier side only.

4. Payment Demand Terms:

50 % ADVANCE payment of Scope Online Transfers, **BALANCE 30 % AFTER START MACHINE WORK WITHIN DESIGN AND 20 % AT THE TIME OF DISPATCHED.** The terms of payment will be as mentioned in our offer for delivery. Any delay in payment beyond stipulated period will carry interest rate at 30 % Per Annum and warrantee of Machine also forfeited.

5. Minimum Order Value:

There are no limitations to the value of the order to be placed on the Company Brand Name is **SPM-MACHINES** However, an order value small so will only be an executed-on receipt of full payment (100 %) along with the confirmation order.

6. Quote Auto Confirmation with Own Terms:

The format of Quotation is digital however if customer given part of advance payment and if they're not send any types of own PO / Release order it means customer already agreed all terms accept of supplier which is mentioned in Quote & standard technical specifications. The Quote & Terms design digitally format so no need any kind of sign or stamp for confirmation any Terms.

7. Currency Fluctuation: (FOR EXPORTS ONLY)

The prices in this quotation are valid subject to the conditions that the Foreign Exchange rates and amounts is vary as per current rate in that day of any amount.

8. Packaging Products Information:

The customer must provide full Products information along with the packing size material order and as per the quotation which will enable to order, in any case buyer side not given trail product material so manufacture will purchase products if easily available and that charges need to pay by buyer / customer accounts.

9. Back Up Software & Electric Diagram:

All software backup, line circuit diagram and related documentation provide by us **(Online only same machine which is sold by us)** as per chargeable basis to Customer are Proprietary and strictly confidential and for use by the customer on the designated product only.

10. Operating Manual & Documentation:

SPM-MACHINES provide machine manuals **if in machines use Higher segment Electricals and higher Industrials Automations parts.** Manual helps first time running of machine. If need additional sets of operating manuals so that an extra amount will be charged.

11. Order Cancellation of Machine / Spares:

If any machine order or any spare part of an order create cancellation by the client side so complete all advance payment will be forfeited which is deposited in account before cancelled against same confirmed of machine or spare parts.

12. Delivery Period of Machine or Parts:

The delivery time of same machine is **90 working days.** Machine Delivery an exact date considers only when timely get supplier demand payments. The delivery date is fluctuates* in case not get timely demand payments or that time get another orders or workloads during customer late payment.

13. Design Failure of Machine or Spare Parts:

After specific an order designed machine totally customized basis and in case after confirmations machine buyer side supplier designed machine fail in customer plant so that supplier need to repair or replace and after that again failure so that machine return back and only EX work amount refund / return (without merge any types of Penalty clause) to client once machine reached supplier works (amount refund condition is when same machine sale any other client then handover basic payment) safety packing, road / sea freight, import duties charges and others charges need to be paid by customer account side only.

14. Warrantee of Assets / Parts of Machine

All standard bought out items e.g. (Gear Box, Sensors, Voltmeters, Electric / Servo Motors, Pneumatic Cylinders, Transformers, other industrial automations and all kind of electrical, automation parts etc.) are not directly covered by our self-warranty. Whatever any kind of warranty is provided by the original manufacturer / OEM (after checking own parameters); the same warranty is made available to our customer. Mechanical components worn-out owing to regular rough use of machine or careless handling are also not covered by warranty. During Warranty period; if we replace any faulty component so customer need to pay payment for same parts or device of new component; faulty component becomes our property so customer has return same.

15. Clearance of Material / Machines:

In case Buyer / Consignee side fails to take delivery of the goods consignment from the Transporters **(TOPAY BASIS)** Go-down within 7 days from the date of dispatch, SPM-MACHINES reserves the right to return back the consignment form buyers cost and risk. The amount adjusts from buyer payments.

16. Inspection of Asset/Machines/Spares

The product offered by us is totally proven and customized design segment according to product packing wise. However, we will agree for an inspection of our machines being carried out at our works by you or which we shall give **Fifteen days' notice.** Inspection will be limited to the facilities available at our Ex works for:

Physically verification and checking at **F.A.T** of the product and general compliances and Functional Checks. After miss Inspection of machines or spares from clients repeat inspection depend on the current condition of machine or spares and in case repeated inspection get any issues in machines or spares so need more time for rectify the problem then re-schedule again Inspection any kind of inspection agencies like: (S.G.S., BEURO) Fees payable by only customer side. We shall offer the product for inspection at customers' site only if agreed contractually. It will be totally customer's responsibility to arrange the necessary peripherals like engineer's team **COME & BACK (AIRFARE, BUS, TRAIN)** along with Loading & Fooding all services.

17. Dispatches of Machines & Spare Parts:

Dispatches shall be made by **ROAD, RAIL, SEA or AIR** to desired destination specified by us on customer behalf and dispatch demand done once full payment received as per total sale bill value of machine or part of any machines.

18. Election and Commissioning of Machines

Our electrical/Mechanical engineers' team will be deputed for the fixing, erection, trail and commissioning of the machines at customer works premises after written confirmation demand. Engineers 'TO and FRO' Charges (Air Fair) along with Boarding and lodging and daily basis service charges (Salary) with local conveyance payable by customer.

19. Transit Loss of Machine or Spare Parts

For safer same customer need to be done transit Inland Road / Marine Insurance before dispatch of machines and during transit any damages or loss case so totally all kind of interaction / communication done Buyer and Insurance company. Supplier side not have any liabilities once machine out / exit from Factory ex works.

20. Short Shipment:

This is very rarely issue come and if any delayed done by supplier side so part other shipment charges payable by supplier side only packing and other charges same as earlier terms according following.